

SHANTILAL SHAH ENGINEERING COLLEGE, BHAVNAGAR
MECHANICAL ENGINEERING DEPARTMENT

List of Drawing Sheet – EGD (3110013) Even Term 2021

(Civil & Mechanical)

Students must prepare sketch book and drawing sheets on the following topics.

1. Practice sheet (which includes dimensioning methods, different types of line, construction of different polygon, divide the line and angle in parts, use of stencil)

2. Plane scale and diagonal scale

1.	Construct a scale of 1:50 to read meters and decimeters and long enough to measure 6 m. Mark on it a distance of 5.5 m.
2.	The distance between two cities is 700kilometers. On inspection of map, it is equivalent of 15 centimeters. Decide Representative Fraction. Draw diagonal scale and indicate on following distances: (1) 610Kilometer (2) 525Kilometer (3) 224Kilometer
3.	The distance between two towns is 250 km and is represented by a line of length 50mm on a map. Construct a scale to read 600 km and indicate a distance of 530 kmon it.

3. Loci of points (only sketch book)

1.	Problem No.14 (Figure No.4.14) page no.45 (P.J.Shah)
2.	The crank OA, 30mm long rotates in anticlockwise direction. The slider C is constraint to slide on the line parallel to a horizontal line passing through O

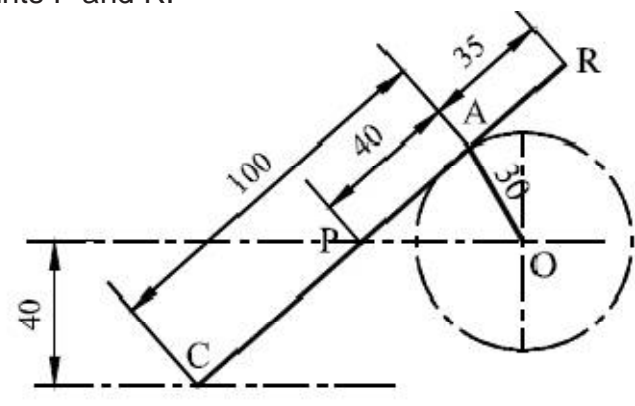
	<p>at a distance of 40mm. The point P is 40mm from A on the connecting link AC=100mm. R is the extension point or rod, 35mm From A. Draw the loci of points P and R.</p> 
3.	Problem No.16 (Figure No.4.16) page no.47 (P.J.Shah)

4. Engineering curves

1.	A stone is thrown from a building of 7 m high and at its highest flight it just crosses a palm tree 14 m high. Trace the path of the stone, if the distance between the building and the tree measured along the ground is 3.5 m.
2.	Construct a conic when the distance of its focus from its directrix is equal to 50 mm and its eccentricity is $\frac{2}{3}$. Name the curve, mark its major axis and minor axis. Draw a tangent at any point, P on the curve.
3.	Draw an epicycloid having a generating circle of diameter 50 mm and a directing curve of radius 100 mm. Also draw a normal and a tangent at any point M on the curve.
4.	Draw an involute of a given pentagon of side, $S=20$ mm, also draw tangent and normal to the curve at given point R.

5. Projection of Points and line

1.	<ol style="list-style-type: none"> 1. Point P is 30 mm. above H.P and 40 mm. in front of VP 2. Point Q is 25 mm. above H.P and 35 mm. behind VP 3. Point R is 32 mm. below H.P and 45 mm behind VP 4. Point S is 35 mm. below H.P and 42 mm in front of VP 5. Point T is in H.P and 30 mm. is behind VP 6. Point U is in VP and 40 mm. below HP 7. Point V is in VP and 35 mm. above H.P 8. Point W is in H.P and 48 mm. in front of VP
2.	A line CD 30 mm long is parallel to both the planes. The line is 40 mm above

	HP and 20 mm in front of V.P. Draw its projection.
3.	A top view of a 75 mm long line AB measures 65 mm, while the length of its front view is 50 mm. Its one end A is in the H.P. and 12 mm in front of the V.P. Draw the projections of AB and determine its inclination with H.P. and the V.P.
4.	A line AB, 90 mm long, is inclined at 30° to the H.P. Its end A is 12 mm above the H.P. and 20 mm in front of the V.P. Its front view measures 65 mm. Draw the top view of AB and determine its inclination with the V.P.
5.	Line AB 75 mm long makes 45° inclination with VP while its Front View makes 55° . End A is 10 mm above HP and 15 mm in front of VP. If line is in 1 st quadrant draw its projections and find its inclination with HP.

6. Projection of plane

1.	A regular triangle side 40 mm is resting on H.P. on one of its sides with surface of the plate perpendicular to V.P. and inclined to H.P. by 55° . Draw its two projections.
2.	A regular pentagonal plate 20 mm side is resting on H.P. on one of its edge. The surface is inclined to H.P. at 45° . The side, on which the plate is resting, makes an angle of 60° to V.P. The corner, opposite to that edge, is nearer to V.P. Draw the projections.
3.	A regular hexagon, 25 mm side, is resting on one of its corner on H.P. the diagonal through that corner is inclined to H.P. such that the plan of that diagonal becomes 30 mm. Find the inclination with H.P. The plan of the diagonal is inclined 30° with V.P. Draw the projections.
4.	A regular hexagonal plate, 30 mm edge, has one of its edges in V.P. and is inclined 55° with H.P. The surface of plate is inclined in such a way that the opposite edge which is in V.P. is 40 mm away from V.P. Draw the projection of plate and find the inclination with V.P.

7. Projection of solid, section of solid and development of surfaces

1.	Problem No.19 (Figure No.11.19) Page no.206 (P.J.Shah)
2.	Problem No.21 (Figure No.11.21) Page no.208 (P.J.Shah)
3.	Problem No.10 (Figure No.12.13) Page no.231 (P.J.Shah)
4.	Problem No.2 (Figure No.13.2) Page no.260 (P.J.Shah)
5.	A right circular cone of base diameter of 50 mm and height 60 mm is resting on HP on its base. Cone is cut by a cutting plane perpendicular to VP and inclined at 30° to HP and passing through a point which is 30 mm away from the apex of cone (bisects the axis of cone). Draw the development of surface of cone.

8. Orthographic projection

1. Draw the following orthographic views. (i) Elevation (ii) Top view (iii) L.H.S.V. Use the 1st angle projection system.

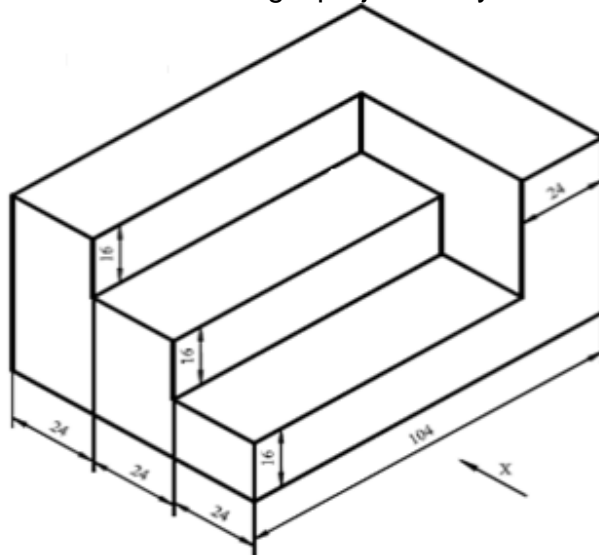

- 2.

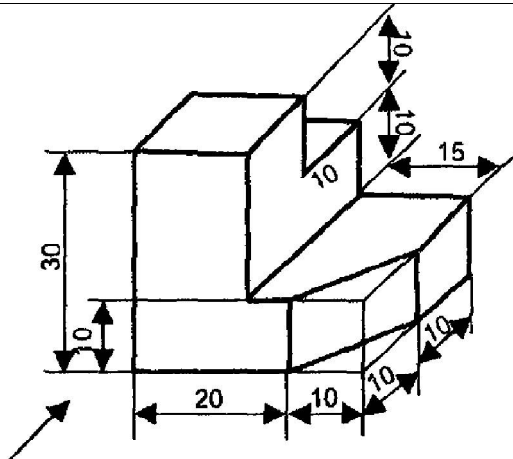

- Draw the following orthographic views. (i) Elevation (ii) Top view (iii) L.H.S.V. Use the 1st angle projection system.

3.

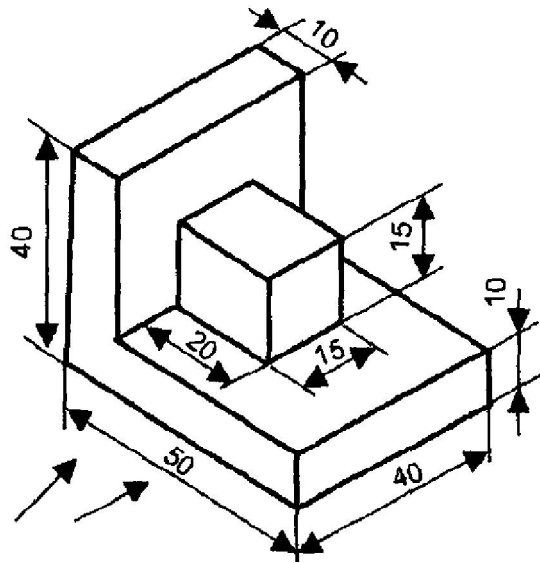

Draw the following orthographic views. (i) Elevation (ii) Top view (iii) L.H.S.V. Use the 3rd angle projection system.

9. Isometric projection

1.

