



SHANTILAL SHAH ENGINEERING COLLEGE, BHAVNAGAR
APPLIED MECHANICS DEPARTMENT

Title of Subject : Mechanics of Solid Date : 20/07/2019
Subject Code : 3130608
Assignment No : 01
Assignment Title : Introduction & Fundamentals of Statics

Q-1: Resultant force of a system of two forces is directed vertically downwards. The magnitude of resultant force R is 50 N. One of the forces of the system has a magnitude of 30 N and is inclined at an angle of 60° with the horizontal as shown in **Fig (1)**. Determine the magnitude P and direction of the second force.

Q-2: Find the resultant of a non-concurrent coplanar force system shown in *Figure No.3* and locate the resultant with respect to point A .

Q-3: Write & Explain Newton's Three laws of Motion

Q-4: Define the following terms: A. Principle of Transmissibility, Principle of Superposition & Law of Gravitation.

Q-5: Explain in brief (i) Resultant of a force system (ii) Law of Parallelogram (iii) Lami's theorem

Q-6: Two buckets are suspended by a flexible wire as shown in *Figure No.02*. The weight of bucket B is 200 N. If the system is in equilibrium, find the weight of bucket A and the force in each part of the wire. Neglect the self-weight of the wire.

Q-7: Calculate shear force and bending moment at salient points for the beam shown in *fig.(4)*. Also plot neat shear force and bending moment diagrams indicating values at above points. Locate the point of contraflexure from support B .

Q-8: Assumptions used in the analysis of Truss & Find Forces in Each member for truss shown in *Figure-5* Using Method of Joints & Method of Section.

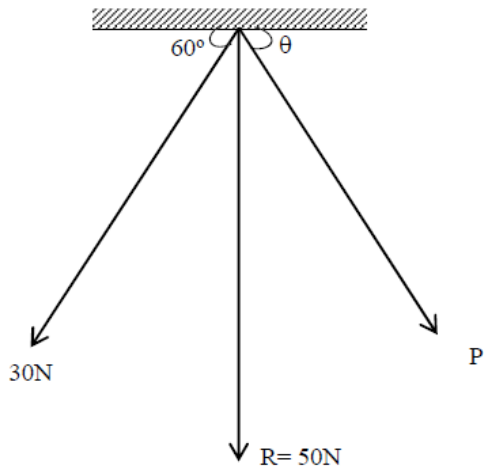

fig. (1)

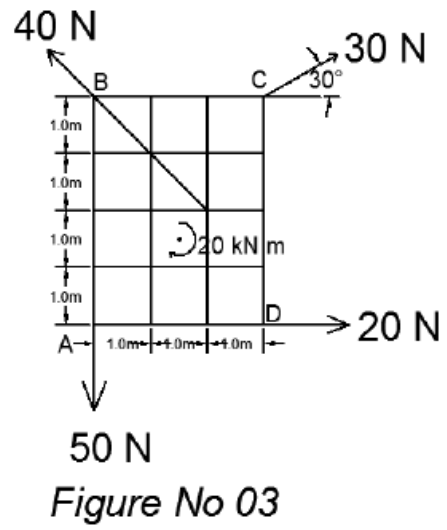

Figure No 03

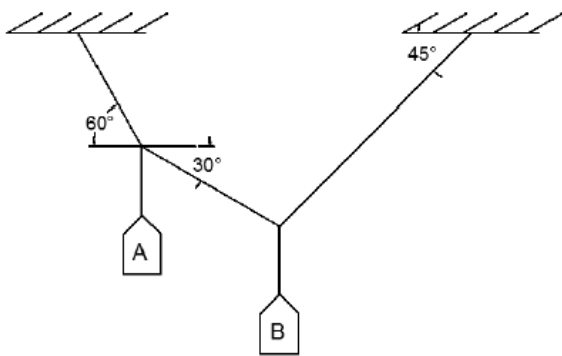

Figure No 02

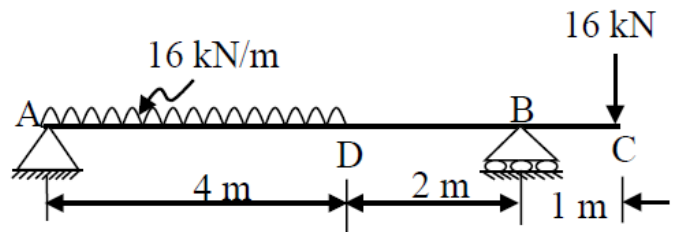
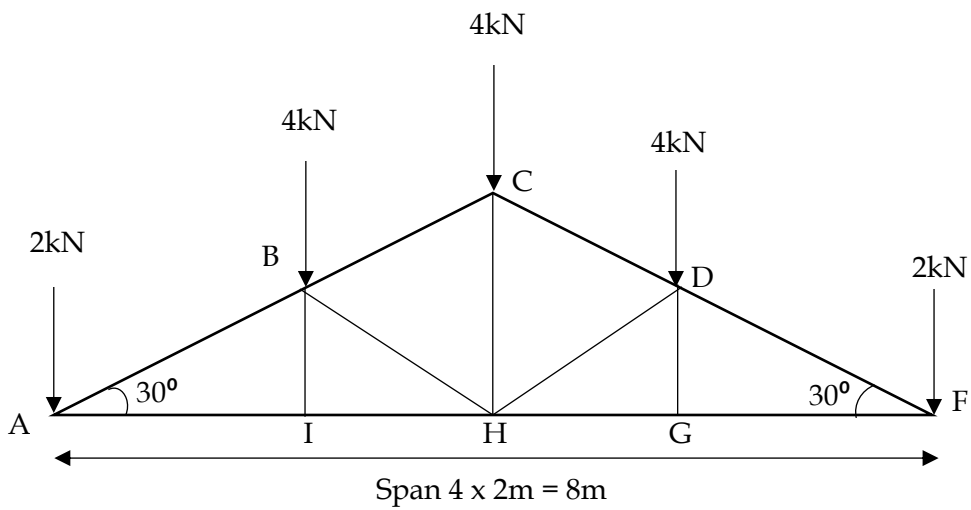

Figure-4



Span $4 \times 2\text{m} = 8\text{m}$

Figure-5



SHANTILAL SHAH ENGINEERING COLLEGE, BHAVNAGAR
APPLIED MECHANICS DEPARTMENT

Title of Subject : Mechanics of Solid Date : 20/07/2019
Subject Code : 3130608
Assignment No : 02
Assignment Title : Applications of fundamentals of statics

Q-1: Describe in detail: Types of Beams, Types of Support & Types of Loads

Q-2: A beam is loaded as shown in *Figure No. 04*, Find the reactions at supports for beam.

Q-3: A beam is loaded as shown in *Figure No. 05*, Find the reactions at Support and draw the shear force and bending moment diagram for the beam, Also determine the maximum bending moment.

Q-4: A mild steel simply supported beam of 3 m span has cross section 20 mm (width) x 50 mm (depth). Find the maximum uniformly distributed load that beam can carry in addition to its self weight, if maximum bending and shear stresses are limited to 150 N/mm² and 100 N/mm². Self weight of beam is 75 N/m.

Q-5: Determine the maximum bending stress and draw bending stress distribution in a section as shown in **Fig.(11)**, if it is subjected to a bending moment of 20kN-m.

Q-6: Determine the maximum shear stress and draw shear stress distribution in a section as shown in **Fig.(11)**, if it is subjected to a shear force of 15kN.

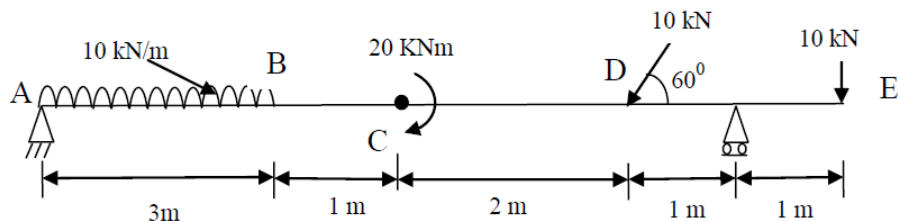

Figure No-4

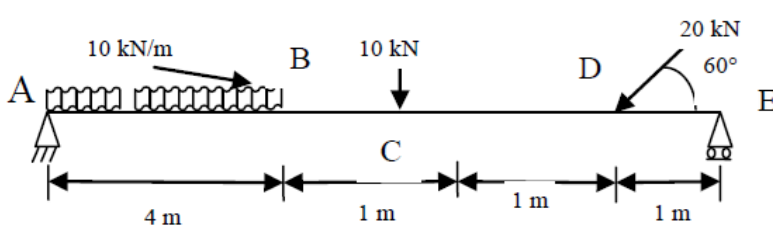

Figure No-5

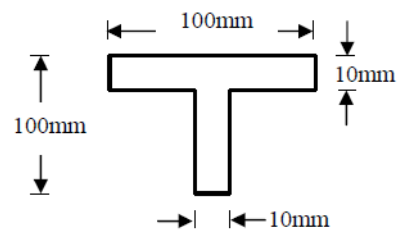

fig. (11)



SHANTILAL SHAH ENGINEERING COLLEGE, BHAVNAGAR
APPLIED MECHANICS DEPARTMENT

Title of Subject : Mechanics of Solid Date : 20/07/2019
Subject Code : 3130608
Assignment No : 03
Assignment Title : Centroid and moment of inertia and mass moment of inertia

Q-1: Describe in detail: Pappus - Guldinus first and second theorems.

Q-2: Find center of gravity of a lamina shown in the fig.5.

Q-3: Find center of gravity of a lamina shown in the fig.7.

Q-4: Find Moment of Inertia of a lamina shown in the fig.8 about horizontal centroidal axis.

Q-5: Determine moment of inertia of section shown in *Figure No.8* about centroidal axes (X and Y both).

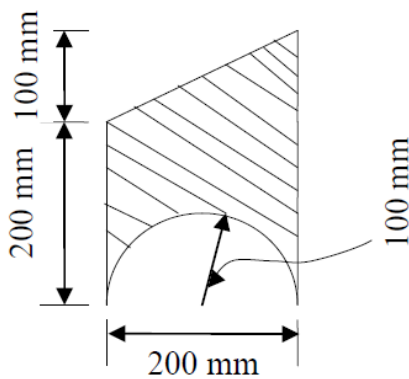

Fig.5

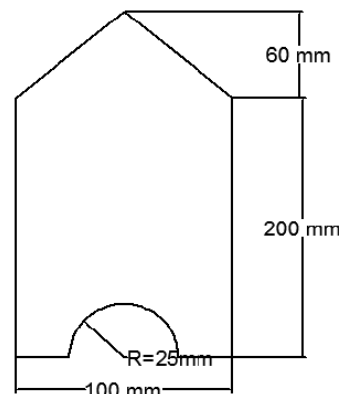

Figure No 07

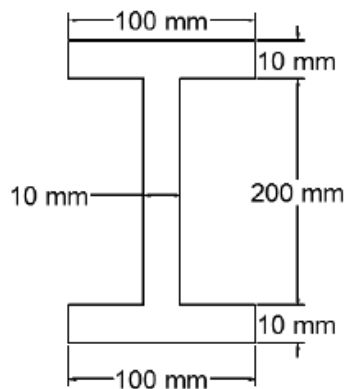

Figure No 4

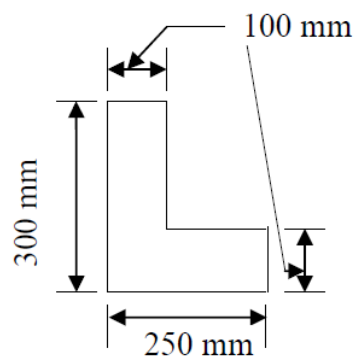

Fig.8



SHANTILAL SHAH ENGINEERING COLLEGE, BHAVNAGAR
APPLIED MECHANICS DEPARTMENT

Title of Subject : Mechanics of Solid
Subject Code : 3130608
Assignment No : 04
Assignment Title : Torsion & Principal Stresses

Date : 20/07/2019

Q-1: Write the assumptions for finding out shear stress in a circular shaft, subjected to torsion. Prove that $\tau/R = C\theta/L$ with usual notations for circular shaft.

Q-2: Determine the minimum diameter of shaft required to transmit 10 kN-m torque. The permissible twist is 1° per meter length and the permissible shear stress of the shaft material is 100MPa. Take modulus of rigidity as 1×10^5 MPa.

Q-3: A solid steel shaft has to transmit 350 kW at 900 r.p.m. Find the diameter of the shaft if the shear stress is to be limited to 125 N/mm². Calculate the diameter of the shaft

Q-4: A machine component is subjected to the stresses as shown in fig. 8. Find the normal and shearing stresses on the section AB inclined at an angle of 60° with horizontal (x-x axis). Also find the resultant stress on the section.

Q-5: At a point in a strained material two mutually perpendicular tensile stress of 5 N/mm² and 8 N/mm² and shear stress 2 N/mm² are acting as shown in Figure No. 09. Find the values of principal stresses and position of principal planes.

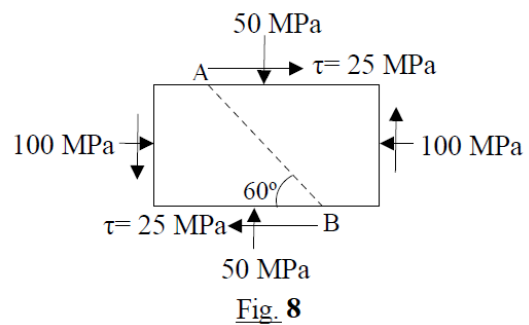
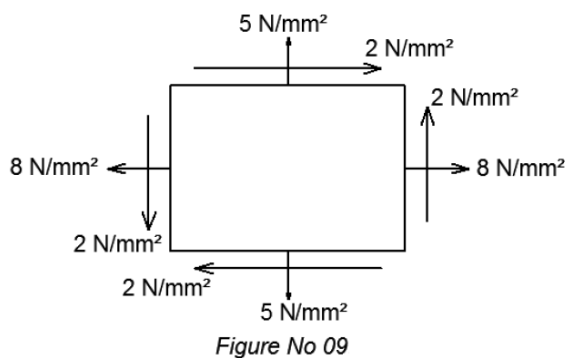



SHANTILAL SHAH ENGINEERING COLLEGE, BHAVNAGAR
APPLIED MECHANICS DEPARTMENT

Title of Subject : Mechanics of Solid
 Subject Code : 3130608
 Assignment No : 04
 Assignment Title : Simple stresses & strains

Date : 20/07/2019

Q-1: Define terms: Hooke's law, Elastic Constants: Modulus of elasticity, Poisson's ratio, Modulus of rigidity and bulk modulus

Q-2: A composite stepped bar made of Brass and Steel as shown in *Figure No. 06*, is subjected to various loads is in equilibrium, Find the unknown force P and total change in length of the bar.

Q-3: A stepped bar made of steel, copper and brass is under axial force as shown in **Figure - 2** and is in equilibrium. The diameter of steel is 12mm, diameter of copper is 16mm and the diameter of brass is 20 mm. Determine (i) Magnitude of unknown force P (ii) stresses in each material and (iii) Total change in length of the bar. Take $E_{\text{steel}} = 200 \text{ GPa}$, $E_{\text{copper}} = 100 \text{ GPa}$ and $E_{\text{brass}} = 80 \text{ GPa}$

Q-4: An assembly of steel bars as shown in the fig.1 is in equilibrium. Find force P and the net elongation of the assembly. Take $E_s = 2 \times 10^5 \text{ MPa}$.

Q-5: A steel circular bar of 16 mm diameter is placed inside a copper tube, having internal diameter of 20 mm and thickness of 2.5 mm as shown in fig.7 . Both the ends are rigidly fixed and initially stress free. If the temperature of assembly is increased by 50°C , compute magnitude and nature of stresses produced in each material. Take modulus of elasticity of steel and copper as 200 GPa and 100 GPa respectively. Take coefficient of thermal expansion (per $^\circ\text{C}$) for steel and copper as 12×10^{-6} and 18×10^{-6} respectively.

